

# ***HAMPTON***

---

Installation, Operation and  
Maintenance Manual

**Vari Speed<sup>®</sup> A2000**

## > TABLE OF CONTENTS

Control Features	2
Options	2
Application Data	3
Operating Conditions	3
Control Ratings Chart	4
Mounting	4
Dimensions	5
Installation and Wiring	8
Typical Wiring Diagram	9
Schematic (Block Diagram)	10
Installation and Wiring continued	12
Component Location	14
Start-Up Procedure	15
Set-Up Procedure	16
Recommended Fuse Chart	19
Trouble Shooting Guide	20

## > CONTROL FEATURES

These features are standard on all VariSpeed A2000 DC controls:

- Run/Stop control from switch
- Speed controlled by potentiometer or 0-10V process signal.
- May be turned on and off via line switching.
- Signal terminal strip requires no wire lugs.
- Power terminal strips with saddle clamps.
- Operates on either 50 or 60 Hertz line without adjustments.
- Transient protected by metal oxide varistor and R-C snubbers.
- Status LED's for power on, run, current limit.
- Armature or tachometer feedback.
- Wide operational speed range.
- Adjustable min/max speed, current limit, IR comp, accel/decel
- Packaging flexibility - Chassis, NEMA 12 (can be field installed).
- 100% factory tested for assured reliability.
- Full two (2) year replacement warranty.
- Chassis units are UL cUL listed for U.S. and Canada.
- Available in 120V, 1/8 to 1HP units and 240V, 1/8 to 3HP units.

## > AVAILABLE OPTIONS

### Isolation:

Two Isolation Options, AGAO and AGBO, are available both featuring easy plug-on assembly to the A2000. Both options allow the use of non-isolated input command signals and 7V or 20.8V/1000 RPM tachometer feedbacks. The AGBO Isolation Option also provides a speed follower and current limit output indication.

### Enclosure:

Three Enclosure Options, NEMA 4 and NEMA 12 with operators and NEMA 4 without operators are available.

If Isolation and/or Enclosure options are used the A2000 is no longer listed by UL, cUL.

## > APPLICATION DATA

Service Factor	- 1.0
Duty	- Continuous
Overload Capability	- 150% for 1 minute
Speed Regulation	- Armature Feedback ±2% Base Speed (for 95% Load Change)
	- Tachometer Feedback ±1/2% Set Speed (for 95% Load Change)
Speed Range	- Armature Feedback 50:1 @ Full Torque
	- Tachometer Feedback 200:1 @ Full Torque
Potentiometers	- 5K Ohm, 1W potentiometer supplied with ease control
Process Signal Input	- 0-10V
Adjustments	- Min. Speed (0-50% of motor base speed)
	- Max. Speed. (50-100% of motor base speed)
	- IR Comp. (0-25% of rate output)
	- Current LIM. (10-15% of Cntrl. Rating)
	- Acceleration ( 1/2-5 Seconds)
	- Deceleration ( 1/2-5 Seconds)

## > OPERATING CONDITIONS

Elevation	- Up to 3300 feet (1000 meters) without derating
Ambient Temperature	- Chassis: 32 - 131°F (0-55°C)
AC Line Voltage Variation	- NEMA 12: 32-104°F ( 0-40°C)
	- Rated Voltage ±10%
AC Line Frequency	- 48 to 62 Hz

## CONTROL RATINGS CHART

Control Rating HP	Control Rating Input Voltage	Rated AC Line Amps*	Rated DC Armature Voltage**	Armature Current Amps	Field Voltage	Field Current Amps
0.5	120	10	0-90	6.8	50/100	1
0.75	120	15	0-90	9.6	50/100	1
1.0	120	20	0-90	12.2	50/100	1
1.0	240	10	0-180	6.1	100/200	1
1.5	240	15	0-180	8.3	100/200	1
2.0	240	20	0-180	10.8	100/200	1
3.0	240	23	0-180	16.0	100/200	1

\*Does not include motor field current where used.

\*\*15% extended voltage capability standard.

## MOUNTING

The VariSpeed A2000 should be mounted horizontally in order to insure maximum heatsink efficiency. With plate units, the plate should be mounted directly against a 12 gauge metal panel measuring at least 13 in. (330 mm) by 15 in. (380 mm).



### CAUTION

On enclosed versions, over tightening cover screws can damage mountings and cover gasket. (Torque specs. 8-12 in. lbs.)

## > STAND ALONE VERSION

Drive shown without protective barrier.

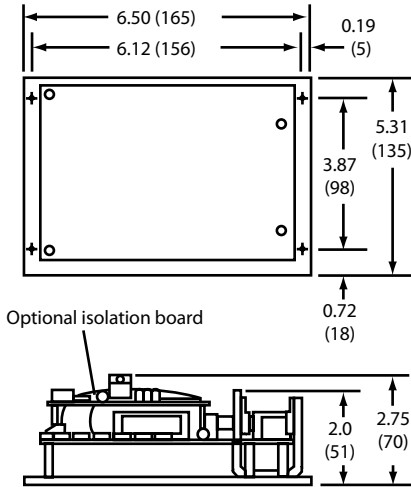

## > CHASSIS PLATE VERSION

Drive shown without protective barrier.

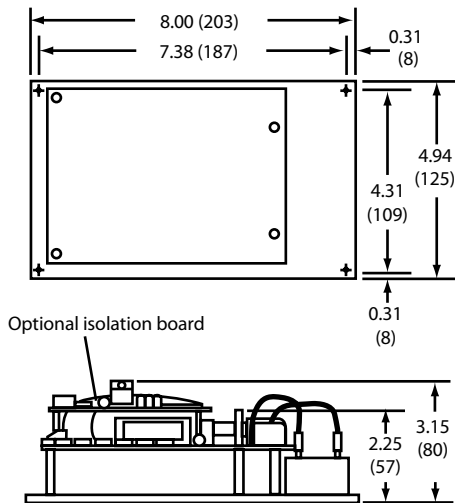

## HEAT SINK VERSION

Drive shown without protective barrier.

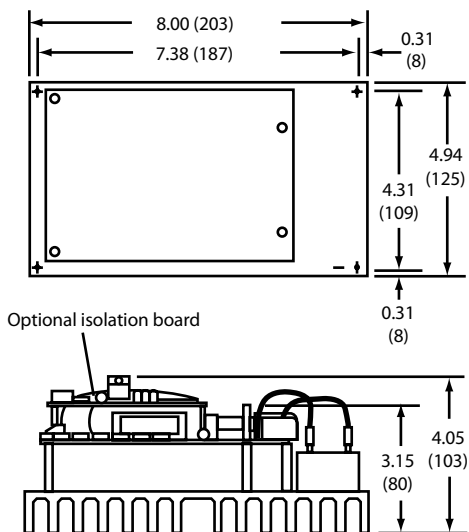

> ENCLOSED PLATE AND ENCLOSED  
HEAT SINK VERSIONS

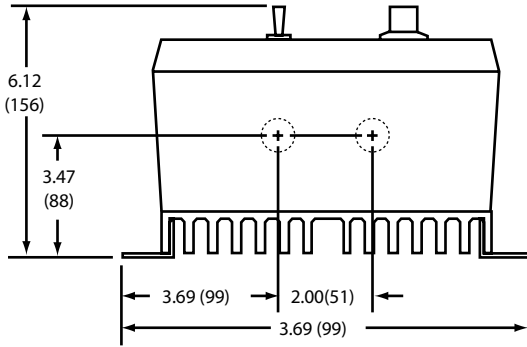
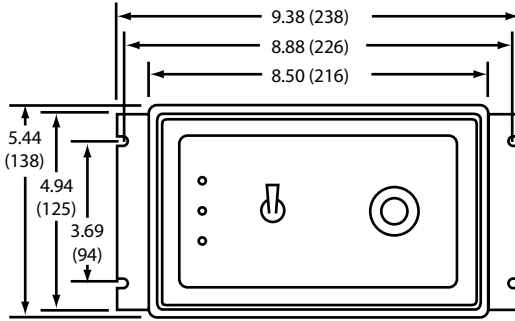



## INSTALLATION AND WIRING

Branch circuit protection and Motor overload protection must be provided by the equipment manufacturer or person installing the controls per the National Electrical Code (NEC) and local codes.

This equipment should be installed, adjusted and serviced by qualified electrical maintenance personnel familiar with the construction and operation of this type of equipment and the hazards involved. It is the responsibility of the equipment manufacturer or person installing the controller to take diligent care. Read this instruction manual and all warnings and notes before proceeding to install or operate this control.



### WARNING

Improper installation of motor and controller may cause equipment failure or serious personal injury. Follow instruction manual, local, state and national safety codes for proper installation. Always disconnect power from the controller before making any wiring changes or before inspecting equipment.

1. Shielded cable recommended but not required.
2. Be certain that a ground wire from the incoming AC power line is properly connected to the chassis ground terminal provided.



### WARNING

Failure to properly ground the control and motor may result in injury or death.

## > INSTALLATION AND WIRING (CONTINUED)

3. The National Electrical code requires a separate fused disconnect be installed in the incoming AC power line. See Ratings Chart and Fuse Chart for proper sizing.
4. All components on the printed circuit board are at line potential. Extreme caution should be exercised when working on unit. Power should always be disconnected from the unit, before any work is attempted, except where required for set-up.
5. DO NOT apply AC line voltage to any terminal except L1 and L2. Failure to comply will cause permanent damage to the control.
6. Automatic restart of the control may occur if line power has been temporarily lost. Caution should be exercised under such circumstances.

## > TYPICAL WIRING DIAGRAM

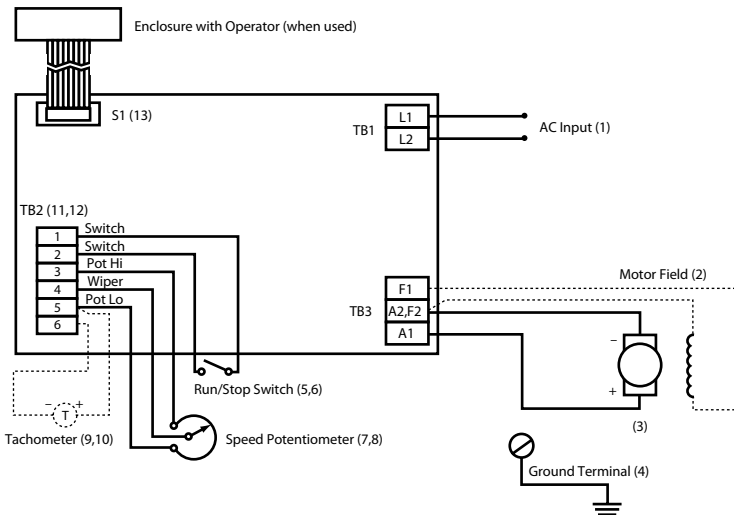

# NOTES

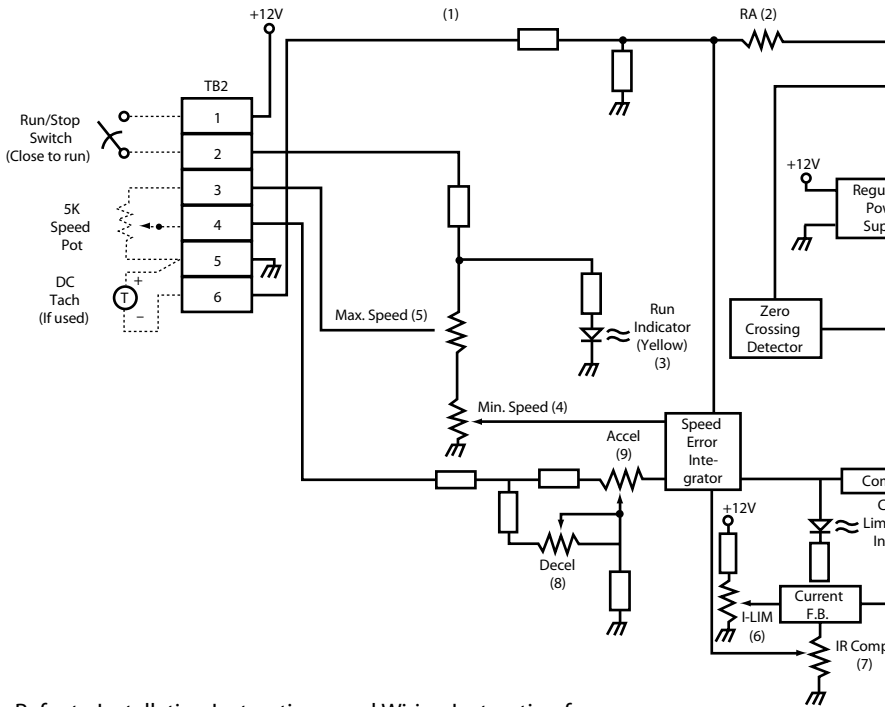

1. Refer to Installation Instructions, and Wiring Instruction for further information
2. Must be removed for tachometer feedback.
3. When optional isolation is used the RUN LED will light on the isolation board.
4. Factory set at OVDC.
5. Factory set for 90VDC for 120V controllers, and 180VDC for 240V controllers.
6. Factory set for 100% of controller rating.
7. Factory set for zero compensation.
8. Factory set for 1/2 second.
9. Factory set for 1/2 second.
10. If half wave field is required, connect between F1 and L2.
11. Shielded cable recommended but not required.

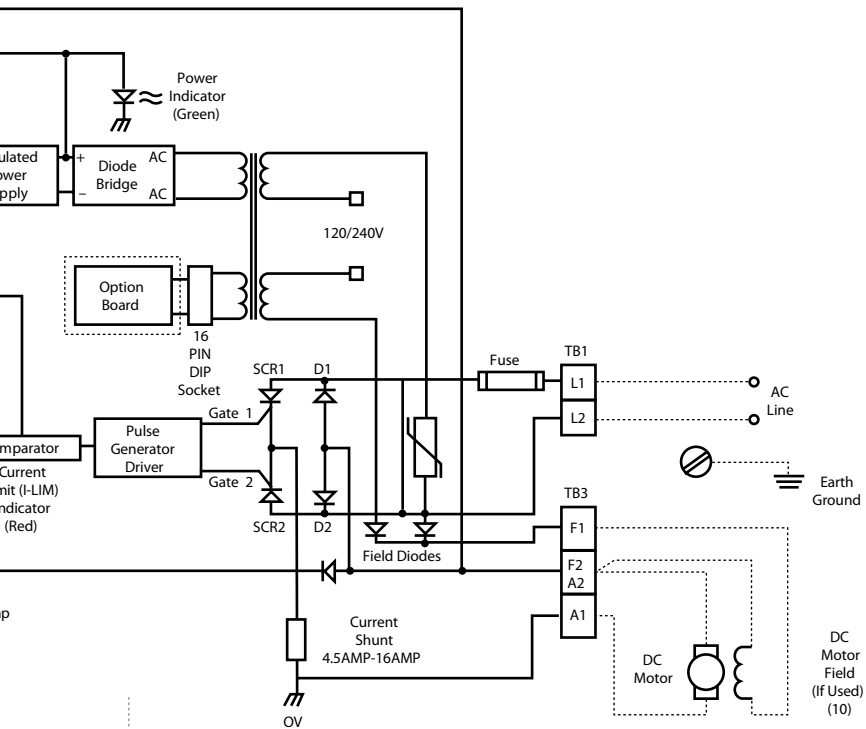

## WIRING (STANDARD AND ENCLOSED UNITS)

Motor overload protection must be provided by the equipment manufacturer or person installing controls per the National Electrical Code.

1. Refer to Rating Chart for incoming line current and voltage. It is the responsibility of the user or person installing the controller to provide branch circuit protection according to the NEC and local codes. On controllers using 120VAC input, be sure that the incoming hot lead is connected to L1 and common is connected to L2.
2. A full wave field is provided for use with shunt wound motors when required. Field voltage on 120VAC line is 100VDC. If the motor requires a 50VDC (half wave) field voltage, connect field windings from F1 to L2. Field voltage on 240VAC line is 200VDC. If the motor requires a 100VDC field, follow the procedure outlined above.
3. Be sure that rated motor current and voltage do not exceed the ratings label on the control. If using a motor with a lower rating than the control, see Recommended Fuse chart for fuse size.
4. A chassis ground terminal has been provided to facilitate grounding of the controller.

### **WARNING**

Be certain that a ground wire from the incoming AC power line is properly connected to the provide terminal. Failure to do this could result in serious injury, equipment failure, or both. Conduit to enclosed units cannot be used for grounding purposes since the enclosure is not metal.

5. The switch provided on enclosed models is RUN/STOP/JOG. Jog speed is determined by speed pot setting.

### **WARNING**

RUN/STOP/JOG switch is for signal switching only. Be certain, before working on either the controller or machine, that AC power is disconnected from L1 and L2 terminals. Failure to do so could result in serious injury or death.

## > WIRING (CONTINUED)

6. A 5K Ohm, 1 Watt rated speed potentiometer is provided with each controller. On chassis versions, a knob and dial plate are also provided.
7. An isolated process signal (0-10V) may be used instead of a potentiometer by connecting signal leads between terminals 4 and 5 on TB3 with positive to terminal 4. 4

Be sure that the signal generated is isolated from ground, or the A2000 and the process signal source will be damaged. For signals that are ground referenced, the optional input signal isolator board must be read.

8. For those applications requiring tachometer feedback the tachometer should be rated for 21VDC per 1000 RPM (with 1800 RPM motor). a
9. When tach feedback is used, the RA resistor (see Component Location drawing) must be removed.
10. S1 socket is provided for use with optional enclosures with operators. Be sure that the ribbon cable is oriented as shown, or equipment failure may result.
11. The TB3 terminal strip will accept wire sizes between #16 and #24 AWG.



### WARNING

All terminals of TB3 are at line potential and can be extremely hazardous. Power must be removed from unit before any wires are connected or disconnected. Wires connected to TB3 must be isolated from ground. Failure to comply may result in injury, equipment failure, or both. Contact with wiring or terminals while power is applied may result in shock, injury, or death.

## COMPONENT LOCATION

Drive shown without protective barrier.

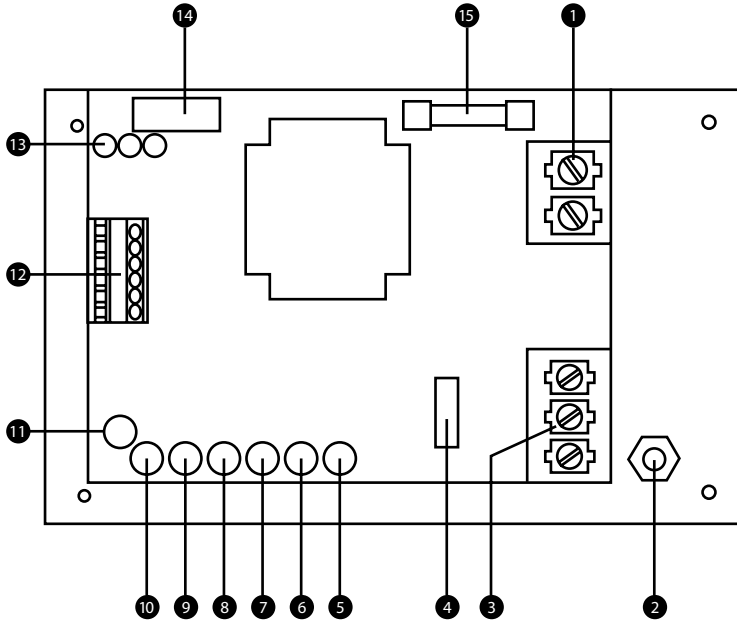

- |                                |                          |
|--------------------------------|--------------------------|
| ① Input (Line) Terminals       | ⑨ Minimum Speed Adjust   |
| ② Chassis Ground (GND)         | ⑩ Deceleration Adjust    |
| ③ Output (Motor) Terminals     | ⑪ Maximum Speed Adjust   |
| ④ RA Resistor                  | ⑫ Control Terminal Strip |
| ⑤ Factory Adjust               | ⑬ Indicator LEDs         |
| ⑥ Current Limit (I-LIM) Adjust | ⑭ Ribbon Cable Socket    |
| ⑦ IR Compensation Adjust       | ⑮ Input Line Fuse        |
| ⑧ Acceleration Adjust          |                          |

## > SET-UP PROCEDURE

Use caution during these procedures because line voltage will be present on the power and motor terminals as well as on the printed circuit board when the power is on.

**NOTE:** If, at any stage of this procedure, the control does not act as indicated, refer to Troubleshooting section.

1. With AC power off, recheck to be sure that all power and control connections are properly secured and connected according to the installation instructions.
2. With enclosed units, be sure that the ribbon cable front the cover is plugged into S1 on the A2000 PC board (or, if used, S3 on the Isolation Option PC board).
3. Set the speed pot to minimum speed (CCW) and place the ON/OFF switch in the OFF position.
4. Apply power to the control and confirm that the POWER ON (green) LED glows. If the LED does not glow refer to the Troubleshooting section.

**NOTE:** On enclosed versions the indicators in the cover glow. The indicators on the printed circuit assembly are disabled by having the cover connected.

5. Place ON/OFF switch in the ON position. The RUN (yellow) LED should glow, but the motor should not turn.
6. Slowly rotate speed pot in a clockwise direction. Motor should begin turning. Continue to rotate speed pot until desired motor speed is achieved.



## SET-UP PROCEDURES

The VariSpeed A2000 has been set up at the factory to satisfy most application needs. You may, however, wish to tailor your control specifically to your application requirements. If so, use the following instruction for proper set-up.

**NOTE:** Before making any adjustments, start control and run motor fully loaded for at least 30 minutes so that motor temperature will stabilize. (Motor speed will increase as temperature increases unless tachometer feedback is used.)

### Factory Settings

Min. Speed	- Zero Volts
Max. Speed	- 90VDC Output for 120VAC line - 180VDC Output for 240VAC line
IR Compensation	- Zero
Accel	- 1/2 Second
Decel	- 1/2 Second

## MINIMUM SPEED ADJUST (MIN)

(Clockwise increases minimum speed)

MIN SPEED may be adjusted from 0 to 50% of motor base speed.

1. Turn speed pot fully counter-clockwise (CCW).
2. Turn MAX SPEED trimpot fully CCW.
3. Adjust MIN SPEED trimpot until desired minimum speed is set. If desired minimum speed is zero, adjust trimpot so that motor barely stops turning. (This will give the best motor speed linearity.)

**NOTE:** If unit will not obtain 0V output with MIN SPEED trimpot fully CCW, turn THRESHOLD trimpot CCW.

4. Reset MAX SPEED ADJUSTMENT.

## > MAX SPEED ADJUSTMENT (MAX)

(Clockwise increases maximum speed)

MAX SPEED may be adjusted from 50% of motor base speed to approximately 115% of base speed.

1. With motor operating at full load, and the speed control knob turned all the way to maximum, adjust the MAX SPEED trimpot until desired speed is set. (NOTE: Extended motor speed can be achieved with the trimpot. Caution should be taken not to exceed maximum motor nameplate speed rating.)
2. Recheck MIN SPEED adjustment, as there may be one interaction.

## > CURRENT (TORQUE) LIMIT ADJUST (I-LIM)

(Clockwise increases current)

I-LIM may be adjusted from 0 to 150% of control rating. There are two methods for adjusting I-LIM.

Method One:

1. Start the machine and apply maximum load to the motor, and turn I-LIM trimpot fully clockwise.
2. Turn the I-LIM trimpot counter-clockwise until the I-LIM LED (red) lights, and the machine starts to slow down.
3. Turn the I-LIM trimpot clockwise until the I-LIM LED just turns off.

Method Two:

1. Turn off AC power
2. Lock up the motor shaft, taking care not to cause damage.
3. Connect a DC ammeter in series with the motor armature.
4. Turn I-LIM trimpot fully counter-clockwise.
5. Turn speed pot fully counter-clockwise.
6. Turn on AC power and start control (red LED should be on).
7. Turn speed pot clockwise to about 1/3 speed setting.
8. Adjust I-LIM trimpot clockwise for desired motor current.  
(Do not set for current greater than either the motor or control nameplate rating.)
9. Turn off AC power, disconnect ammeter, and unlock motor shaft.

## > IR COMPENSATION ADJUST

(Clockwise increases compensation)

If tachometer feedback is used, be sure that this adjustment is set fully counter-clockwise. IR Compensation should not be used with tachometer feedback.

This adjustment is provided to overcome the motor's natural tendency to slow down with increasing load. If improved load/speed performance is required, this adjustment may be used.

NOTE: In order to optimize performance with this adjustment, some means of determining motor shaft speed is required. (i.e., hand held tachometer).

1. Set motor speed to 1/2 of base speed rating or to the speed where the greatest accuracy is required and motor load to minimum.
2. Load motor to 100% nameplate rating.
3. Turn IR COMP clockwise until motor returns to original unloaded RPM.
4. Turn off load and notice if RPM increases beyond original setting. If so, adjust trimpot while changing from no load to full load to give minimum RPM change for each.

NOTE: Setting IR COMP too high can cause motor speed instability, Turn IR COMP pot counter-clockwise until motor speed stability is achieved.

### Acceleration (ACCEL)/Deceleration DECEL Adjustments

Set these two trim pots for desired times. Both ACCEL and DECEL trim pots adjust from 1/2 to 5 seconds. Acceleration time may be extended with I-LIM if reflected inertia is high. DECEL may also be longer if reflected inertia is high.

## > RECOMMENDED AC LINE PROTECTION FUSE CHART

AC Line Voltage	Motor Horsepower	Dual Element Fuse Amps
120	1/8	2.5
	1/4	4
	1/3	5
	1/2	10
	3/4	15
	1	20
	1/8	1.5
	1/4	2
240	1/3	2.5
	1/2	4
	3/4	5
	1	10
	1-1/2	15
	2	20
	3	25

## > TROUBLE SHOOTING GUIDE

### Motor will not run:

1. Make sure power LED is lit. If not, make sure disconnect fuses or circuit breaker in line are okay.
2. Check line fuse. If open, replace. (See Fuse Chart)
3. Make sure "RUN" switch is on. (RUN LED should be lit.)
4. Be sure speed pot is not set to zero.
5. Unit is in current (torque limit). Check I-LIM LED (if lit, this indicates that I-LIM pot is set too low or motor is overloaded).
6. With power removed from unit and motor leads disconnected, check for worn or improperly seated brushes.
7. Defective control.

### Fuse blowing:

1. Improper wiring.
2. Motor brushes worn or improperly seated.
3. Motor load is too heavy. Check for machine "jam-up" or excessive load.
4. Defective control. If the control has failed, always check the motor and wiring for short circuits and grounding before replacing the control.

### No speed control:

1. Speed pot or wiring defective.
2. Control not set up properly. (See Set-up Procedures)
3. Defective Control.

### Motor will not run at 1725 RPM:

1. Improper setting of MAX speed trim pot. (Range trim pot